

# JEE (Main) PHYSICS SOLVED PAPER

**2023**  
08<sup>th</sup> April Shift 2

## General Instructions :

- (i) There are 30 questions in this section.
- (ii) Section A consists of 20 Multiple choice questions and Section B consists of 10 Numerical value type questions. In Section B, candidates have to attempt any five questions out of 10.
- (iii) There will be only one correct choice in the given four choices in Section A. For each question for Section A, 4 marks will be awarded for correct choice, 1 mark will be deducted for incorrect choice questions and zero mark will be awarded for not attempted questions.
- (iv) For Section B questions, 4 marks will be awarded for correct answer and zero for unattempted and incorrect answer.
- (v) Any textual, printed or written material, mobile phones, calculator etc. is not allowed for the students appearing for the test.
- (vi) All calculations/ written work should be done in the rough sheet which is provided with Question Paper.

## Section A

- Q. 1.** A hydraulic automobile lift is designed to lift vehicles of mass 5000 kg. The area of cross section of the cylinder carrying the load is  $250 \text{ cm}^2$ . The maximum pressure the smaller piston would have to bear is [Assume  $g = 10 \text{ m/s}^2$ ]:  
**(A)**  $2 \times 10^{+5} \text{ Pa}$       **(B)**  $20 \times 10^{+6} \text{ Pa}$   
**(C)**  $200 \times 10^{+6} \text{ Pa}$       **(D)**  $2 \times 10^{+6} \text{ Pa}$
- Q. 2.** The orbital angular momentum of a satellite is  $L$ , when it is revolving in a circular orbit at height  $h$  from earth surface. If the distance of satellite from the earth center is increased by eight times to its initial value, then the new angular momentum will be-  
**(A)**  $8L$       **(B)**  $3L$   
**(C)**  $4L$       **(D)**  $9L$
- Q. 3.** The waves emitted when a metal target is bombarded with high energy electrons are  
**(A)** Microwaves      **(B)** X-rays  
**(C)** Radio Waves      **(D)** Infrared rays
- Q. 4.** Match List I with List II:

LIST-I		LIST-II	
<b>A.</b>	Torque	<b>I.</b>	$\text{ML}^{-2}\text{T}^{-2}$
<b>B.</b>	Stress	<b>II.</b>	$\text{ML}^2\text{T}^{-2}$
<b>C.</b>	Pressure gradient	<b>III.</b>	$\text{ML}^{-1}\text{T}^{-1}$
<b>D.</b>	Coefficient of viscosity	<b>IV.</b>	$\text{ML}^{-1}\text{T}^{-2}$

- Choose the correct answer from the options given below:  
**(A)** A-III, B-IV, C-I, D-II  
**(B)** A-II, B-I, C-IV, D-III  
**(C)** A-IV, B-II, C-III, D-I

**(D)** A-II, B-IV, C-I, D-III

- Q. 5.** Give below are two statements  
**Statement I :** Area under velocity- time graph gives the distance travelled by the body in a given time.  
**Statement II :** Area under acceleration- time graph is equal to the change in velocity- in the given time.  
 In the light of given statement, choose the correct answer from the options given below  
**(A)** Both Statement I and Statement II are true.  
**(B)** Statement I is correct but Statement II is false.  
**(C)** Both Statement I and and Statement II are false  
**(D)** Statement I is incorrect but Statement II is true.
- Q. 6.** The power radiated from a linear antenna of length  $l$  is proportional to (Given,  $\lambda =$  Wavelength of wave):  
**(A)**  $\frac{l}{\lambda}$       **(B)**  $\frac{l^2}{\lambda}$   
**(C)**  $\frac{l}{\lambda^2}$       **(D)**  $\left(\frac{l}{\lambda}\right)^2$
- Q. 7.** Electric potential at a point 'P' due to a point charge of  $5 \times 10^{-9} \text{ C}$  is 50 V. The distance of 'P' from the point charge is:  
 (Assume,  $\frac{1}{4\pi\epsilon_0} = 9 \times 10^{+9} \text{ Nm}^2\text{C}^{-2}$ )  
**(A)** 3 cm      **(B)** 9 cm  
**(C)** 0.9 cm      **(D)** 90 cm
- Q. 8.** The acceleration due to gravity at height  $h$  above the earth if  $h < R$  (Radius of earth) is given by  
**(A)**  $g' = g \left(1 - \frac{h^2}{2R^2}\right)$       **(B)**  $g' = g \left(1 - \frac{h}{2R}\right)$

(C)  $g' = g \left( 1 - \frac{2h^2}{R^2} \right)$       (D)  $g' = g \left( 1 - \frac{2h}{R} \right)$

Q. 9. An emf of 0.08 V is induced in a metal rod of length 10 cm held normal to a uniform magnetic field of 0.4 T, when moves with a velocity of:  
 (A)  $2 \text{ ms}^{-1}$                       (B)  $20 \text{ ms}^{-1}$   
 (C)  $3.2 \text{ ms}^{-1}$                       (D)  $0.5 \text{ ms}^{-1}$

Q. 10. Work done by a Carnot engine operating between temperatures  $127^\circ\text{C}$  and  $27^\circ\text{C}$  is 2 kJ. The amount of heat transferred to the engine by the reservoir is:  
 (A) 2 kJ                                  (B) 4 kJ  
 (C) 2.67 kJ                              (D) 8 kJ

Q. 11. The width of fringe is 2 mm on the screen in a double slits experiment for the light of wavelength of 400 nm. The width of the fringe for the light of wavelength 600 nm will be:  
 (A) 1.33 mm                              (B) 3 mm  
 (C) 2 mm                                  (D) 4 mm

Q. 12. The temperature at which the kinetic energy of oxygen molecules becomes double than its value at  $27^\circ\text{C}$  is  
 (A)  $1227^\circ\text{C}$                               (B)  $627^\circ\text{C}$   
 (C)  $327^\circ\text{C}$                                 (D)  $927^\circ\text{C}$

Q. 13. Given below are two statements : one is labelled as Assertion A and the other is labelled as Reason R  
**Assertion A** : Electromagnets are made of soft iron.  
**Reason R** : Soft iron has high permeability and low retentivity.  
 In the light of above, statements, chose the most appropriate answer from the options given below  
 (A) A is correct but R is not correct  
 (B) Both A and R are correct and R is the correct explanation of A  
 (C) Both A and R are correct but R is NOT the correct explanation of A  
 (D) A is not correct but R is correct

Q. 14. The trajectory of projectile, projected from the ground is given by  $y = x - \frac{x^2}{20}$ . Where  $x$  and  $y$  are measured in meter. The maximum height attained by the projectile will be.  
 (A) 10 m                                  (B) 200 m  
 (C)  $10\sqrt{2}$  m                              (D) 5 m

Q. 15. A bullet of mass 0.1 kg moving horizontally with speed  $400 \text{ ms}^{-1}$  hits a wooden block of mass 3.9 kg kept on a horizontal rough surface. The bullet gets embedded into the block and moves 20 m before coming to rest. The coefficient of friction between the block and the surface is \_\_\_\_\_.  
 (Given  $g = 10 \text{ m/s}^2$ )  
 (A) 0.90                                  (B) 0.65  
 (C) 0.25                                  (D) 0.50

Q. 16. For a given transistor amplifier circuit in CE configuration  $V_{CC} = 1 \text{ V}$ ,  $R_C = 1 \text{ k}\Omega$ ,  $R_b = 100 \text{ k}\Omega$  and  $\beta = 100$ . Value of base current  $I_b$  is

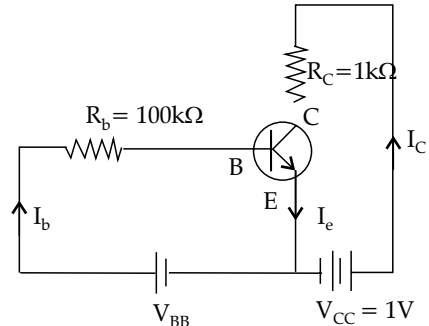

(A)  $I_b = 100 \mu\text{A}$                       (B)  $I_b = 10 \mu\text{A}$   
 (C)  $I_b = 0.1 \mu\text{A}$                       (D)  $I_b = 1.0 \mu\text{A}$

Q. 17. For particle P revolving round the centre O with radius of circular path  $r$  and angular velocity  $\omega$ , as shown in below figure, the projection of OP on the  $x$ -axis at time  $t$  is

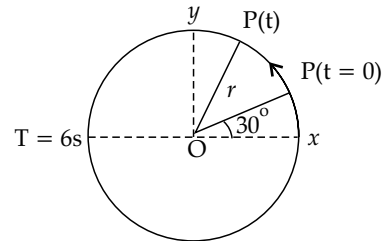

(A)  $x(t) = r \cos \left( \omega t + \frac{\pi}{6} \right)$   
 (B)  $x(t) = r \cos \left( \omega t - \frac{\pi}{6} \right)$   
 (C)  $x(t) = r \cos (\omega t)$   
 (D)  $x(t) = r \sin \left( \omega t + \frac{\pi}{6} \right)$

Q. 18. A radio active material is reduced to  $1/8$  of its original amount in 3 days. If  $8 \times 10^{-3} \text{ kg}$  of the material is left after 5 days the initial amount of the material is  
 (A) 64 g                                  (B) 40 g  
 (C) 32 g                                  (D) 256 g

Q. 19. The equivalent resistance between A and B as shown in figure is:

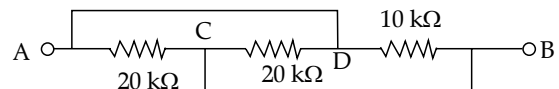

(A) 20 kΩ                                  (B) 30 kΩ  
 (C) 5 kΩ                                  (D) 10 kΩ

Q. 20. In photo electric effect  
 A. The photocurrent is proportional to the intensity of the incident radiation.  
 B. Maximum Kinetic energy with which photoelectrons are emitted depends on the intensity of incident light.

C. Max K.E with which photoelectrons are emitted depends on the frequency of incident light.

D. The emission of photoelectrons require a minimum threshold intensity of incident radiation.

E. Max. K.E of the photoelectrons is independent of the frequency of the incident light.

Choose the correct answer from the options given below:

- (A) B and C only      (B) A and C only  
(C) A and E only      (D) A and B only

### Section B

- Q. 21. A 600 pF capacitor is charged by 200 V supply. It is then disconnected from the supply and is connected to another uncharged 600 pF capacitor. Electrostatic energy lost in the process is \_\_\_\_\_  $\mu\text{J}$
- Q. 22. A series combination of resistor of resistance 100  $\Omega$ , inductor of inductance 1 H and capacitor of capacitance 6.25  $\mu\text{F}$  is connected to an ac source. The quality factor of the circuit will be \_\_\_\_\_
- Q. 23. The number density of free electrons in copper is nearly  $8 \times 10^{28} \text{ m}^{-3}$ . A copper wire has its area of cross section =  $2 \times 10^{-6} \text{ m}^2$  and is carrying a current of 3.2 A. The drift speed of the electrons is \_\_\_\_\_  $\times 10^{-6} \text{ ms}^{-1}$
- Q. 24. A hollow spherical ball of uniform density rolls up a curved surface with an initial velocity 3 m/s (as shown in figure). Maximum height with respect to the initial position covered by it will be \_\_\_\_\_ cm (take,  $g = 10 \text{ m/s}^2$ )

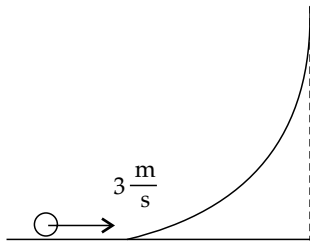

- Q. 25. A steel rod of length 1 m and cross sectional area  $10^{-4} \text{ m}^2$  is heated from  $0^\circ\text{C}$  to  $200^\circ\text{C}$  without being allowed to extend or bend. The compressive tension produced in the rod is \_\_\_\_\_  $\times 10^4 \text{ N}$ . (Given Young's modulus of steel =  $2 \times 10^{11} \text{ Nm}^{-2}$ , coefficient of linear expansion =  $10^{-5} \text{ K}^{-1}$ )
- Q. 26. The ratio of magnetic field at the centre of a current carrying coil of radius r to the magnetic field at distance from the centre of coil on its axis is  $\sqrt{x} : 1$ . The value of x is \_\_\_\_\_
- Q. 27. The ratio of wavelength of spectral lines  $H_\alpha$  and  $H_\beta$  in the Balmer series is  $\frac{x}{20}$ . The value of x is \_\_\_\_\_.
- Q. 28. Two transparent media having refractive indices 1.0 and 1.5 are separated by a spherical refracting surface of radius of curvature 30 cm. The centre of curvature of surface is towards denser medium and a point object is placed on the principle axis in rarer medium at a distance of 15 cm from the pole of the surface. The distance of image from the pole of the surface is \_\_\_\_\_ cm.
- Q. 29. A guitar string of length 90 cm vibrates with a fundamental frequency of 120 Hz. The length of the string producing a fundamental frequency of 180 Hz will be \_\_\_\_\_ cm.
- Q. 30. A body of mass 5 kg is moving with a momentum of  $10 \text{ kg ms}^{-1}$ . Now a force of 2 N acts on the body in the direction of its motion for 5 s. The increase in the Kinetic energy of the body is \_\_\_\_\_ J.

## Answer Key

Q. No.	Answer	Topic Name	Chapter Name
1	D	Pascal's law	Fluid mechanics
2	B	Satellite	Gravitation
3	B	X ray	EM waves
4	D	Dimension	Units & Dimensions
5	D	v-t and a-t graph	Motion in One Dimension
6	D	Power of antenna	Communication System
7	D	Electric potential	Electrostatics
8	D	Acceleration due to gravity	Gravitation
9	A	Induced EMF	Electromagnetic Induction
10	D	Carnot engine	Thermodynamics
11	B	YDSE	Wave optics
12	C	Kinetic energy of gas	Kinetic theory of gasses
13	B	Electromagnet	Electromagnetism
14	D	Projectile	Motion in 2D
15	C	Momentum conservation	Collision
16	B	Transistor	Semiconductors
17	A	Phasor	Circular Motion
18	D	Half life	Nuclear Physics
19	C	Resistance circuit	Electric Current
20	B	Kinetic Energy of photoelectron	Photoelectric Effect
21	[6]	Energy in capacitors	Capacitors
22	[4]	RLC circuit	Electromagnetic Induction
23	[125]	Drift velocity	Electric current
24	[75]	Rotational Kinetic Energy	Rotational Motion
25	[4]	Thermal stresses	Elasticity
26	[8]	Magnetic field due to current carrying loop	Magnetism
27	[27]	Hydrogen spectra	Atoms
28	[30]	Refraction through spherical surfaces	Ray optics
29	[60]	Fundamental Frequency	Sound waves
30	[30]	Change in Kinetic Energy	Work, Energy and Power

# JEE (Main) PHYSICS SOLVED PAPER

**2023**  
08<sup>th</sup> April Shift 2

## ANSWERS WITH EXPLANATIONS

### Section A

1. **Option (D) is correct.**

Given,  $m = 5000 \text{ kg}$   
 $A = 250 \text{ cm}^2 = 250 \times 10^{-4} \text{ m}^2$   
 $F = mg = 5000 \times 10 = 50000 \text{ N}$   
 From Pascal's law pressure would be same at both ends of piston.

$$P = \frac{F}{A}$$

$$P = \frac{50000}{250 \times 10^{-4}} = 2 \times 10^6 \text{ Pa}$$

2. **Option (B) is correct.**

Angular momentum is given by

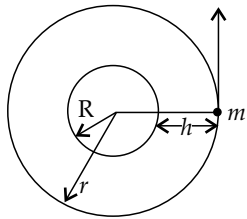

$$L = mvr$$

where  $v = \sqrt{\frac{GM}{r}}$

$$L = m \sqrt{\frac{GM}{r}} \times r = m \sqrt{\frac{GM r^2}{r}} = \sqrt{GM} r$$

$$L \propto r^{\frac{1}{2}}$$

Now, the new distance from centre =  $r + 8r = 9r$

New angular momentum

$$L' \propto (9r)^{\frac{1}{2}}$$

Therefore,

$$\frac{L'}{L} = \frac{(r)^{\frac{1}{2}}}{(9r)^{\frac{1}{2}}} = \frac{1}{3}$$

$$\Rightarrow L' = 3L$$

3. **Option (B) is correct.**

When target metal is bombarded with high energy electron then X-rays are emitted.

4. **Option (D) is correct.**

A.  $\vec{\tau} = \vec{r} \times \vec{F}$

$$[\tau] = [L] [MLT^{-2}] = ML^2T^{-2}$$

B.  $\sigma = \frac{F}{A} = \frac{MLT^{-2}}{L^2} = ML^{-1}T^{-2}$

C.  $\frac{\Delta P}{\Delta x} = \frac{\left[\frac{F}{A}\right]}{L} = ML^{-2}T^{-2}$

D.  $F = 6\pi\eta rV$   
 $\Rightarrow MLT^{-2} = [\eta] L^2 T^{-1}$

$$\Rightarrow [\eta] = ML^{-1}T^{-1}$$

5. **Option (D) is correct.**

$$\vec{S} = \int \vec{V} dt$$

Therefore area under velocity time graph gives displacement.

Hence statement-I is false.

Area under acceleration time graph gives change in velocity.

$$a = \frac{dV}{dt}$$

$$\Rightarrow dV = a dt$$

$$\Rightarrow \int dV = \int a dt$$

Hence statement-II is correct.

6. **Option (D) is correct.**

Radiating power of linear antenna is given by,

$$P = \frac{\pi}{12} I_0^2 Z_0 \left(\frac{l}{\lambda}\right)^2$$

Hence,

$$P \propto \left(\frac{l}{\lambda}\right)^2$$

7. **Option (D) is correct.**

Given,  $q = 5 \times 10^{-9} \text{ C}$

$V = 50 \text{ V}$

$$V = k \frac{q}{r} \quad \left( k = \frac{1}{4\pi\epsilon_0} = 9 \times 10^9 \frac{\text{Nm}^2}{\text{C}^2} \right)$$

$$\Rightarrow 50 = \frac{9 \times 10^9 \times 5 \times 10^{-9}}{r}$$

$$\Rightarrow r = \frac{9 \times 5}{10} = 0.9 \text{ m} = 90 \text{ cm}$$

8. **Option (D) is correct.**

$$g = \frac{GM}{R^2}$$

...(i)

Now acceleration due to gravity at height  $h$  is given by

$$g' = \frac{GM}{(R+h)^2} = \frac{GM}{R^2 \left(1 + \frac{h}{R}\right)^2}$$

$$\Rightarrow g' = \frac{g}{\left(1 + \frac{h}{R}\right)^2}$$

$$\left( \because \text{from (i)} g = \frac{GM}{R^2} \right)$$

$$\Rightarrow g' = g \left(1 + \frac{h}{R}\right)^{-2}$$

$$\Rightarrow g' = g \left(1 - \frac{2h}{R}\right) \text{ from binomial expansion.}$$

9. **Option (A) is correct.**

When a metal rod is held normal moving in uniform magnetic field then the induced emf is given by  
Induced  $E = Blv$

$$\Rightarrow v = \frac{E}{Bl} = \frac{0.08}{0.4 \times \frac{10}{100}}$$

$$v = 0.08 \times 100 / 0.4 \times 10 = 2 \text{ m/s}$$

10. **Option (D) is correct.**

Efficiency of a carnot engine is given by

$$\eta = 1 - \frac{T_2}{T_1} = \frac{W}{Q_1}$$

$$\text{where } T_1 = 127 + 273 = 400\text{K}$$

$$T_2 = 27 + 273 = 300\text{K}$$

Therefore,

$$\frac{W}{Q_1} = 1 - \frac{T_2}{T_1} = 1 - \frac{300}{400}$$

$$\Rightarrow \frac{2 \times 10^3 \text{ J}}{Q_1} = \frac{1}{4}$$

$$\Rightarrow Q_1 = 8 \times 10^3 \text{ J} = 8 \text{ kJ}$$

11. **Option (B) is correct.**

Given,  $\beta_1 = 2\text{mm}$ ,  $\lambda_1 = 400 \text{ nm}$

$\beta_2 = ?$ ,  $\lambda_2 = 600 \text{ nm}$

$$\text{Fringe width } (\beta) = \frac{D\lambda}{d}$$

$$\beta_1 = \frac{D\lambda_1}{d}$$

$$\beta_2 = \frac{D\lambda_2}{d}$$

$$\Rightarrow \frac{\beta_1}{\beta_2} = \frac{\lambda_1}{\lambda_2}$$

$$\Rightarrow \frac{2\text{mm}}{\beta_2} = \frac{400 \text{ nm}}{600 \text{ nm}} = \frac{2}{3}$$

$$\Rightarrow \beta_2 = \frac{2 \times 3}{2} \text{ mm} = 3\text{mm}$$

12. **Option (C) is correct.**

Kinetic energy is given by

$$K = \frac{f}{2}KT$$

$$K \propto T$$

Therefore,

$$\frac{K_1}{K_2} = \frac{T_1}{T_2}$$

$$\Rightarrow \frac{1}{2} = \frac{(27 + 273)}{T_2}$$

$$\Rightarrow T_2 = 2 \times 300\text{K}$$

$$\Rightarrow T_2 = 600 \text{ K} = 327 \text{ C}$$

13. **Option (B) is correct.**

Soft iron has high permeability and low retentivity.

Therefore, iron is used to make electromagnet.

So, both A & R are correct and R is the correct explanation of A.

14. **Option (D) is correct.**

$$y = x - \frac{x^2}{20}$$

...(i)

$$\frac{dy}{dx} = 0$$

(For maximum height)

$$\Rightarrow \frac{dy}{dx} = 1 - \frac{2x}{20} = 0$$

$$\Rightarrow 20 - 2x = 0$$

$$\Rightarrow x = 10$$

Putting the value of  $x$  in (i) for  $y_{\text{max}}$ .

$$y = x - \frac{x^2}{20}$$

$$\Rightarrow y_{\text{max}} = 10 - \frac{100}{20}$$

$$= 10 - 5 = 5 \text{ m}$$

15. **Option (C) is correct.**

Momentum of bullet before collision

$$P_i = 0.1 \times 400 = 40 \text{ N-s}$$

Momentum after collision

$$P_f = (0.1 + 3.9)v$$

Applying conservation of momentum

$$P_i = P_f$$

$$\Rightarrow 40 = (0.1 + 3.9)v$$

$$\Rightarrow v = 10\text{m/s}$$

$$\text{Now, } v^2 = u^2 + 2as$$

$$\Rightarrow 0 = (10)^2 - 2 \times a \times 20 \quad (u = 10 \text{ m/s after collision})$$

$$\Rightarrow 40a = 100$$

$$\Rightarrow a = \frac{10}{4} = 2.5 \text{ m/s}^2$$

$$\text{So, } F = ma$$

$$\Rightarrow \mu mg = ma$$

$$\Rightarrow a = \mu g$$

$$\Rightarrow \mu = \frac{a}{g} = \frac{2.5}{10} = 0.25$$

16. **Option (B) is correct.**

In saturation mode  $V_{CE} = 0$

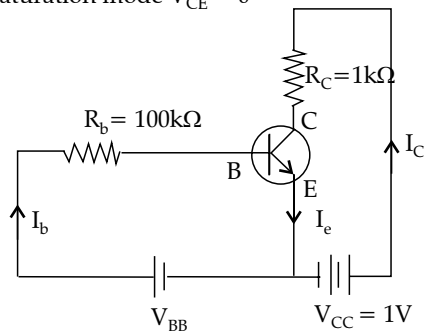

Now

$$V_{CC} - I_c R_c = 0$$

(from KVL)

$$\Rightarrow I_b = \frac{V_{CC}}{R_c} = \frac{1}{1 \times 10^3} = 10^{-3} \text{ A}$$

Given that

$$\beta = 100 = \frac{I_c}{I_b}$$

$$\Rightarrow I_b = \frac{I_c}{100} = \frac{10^{-3}}{100} = 10^{-5} \text{ A}$$

$$\Rightarrow I_b = 10 \mu\text{A}$$

17. Option (A) is correct.

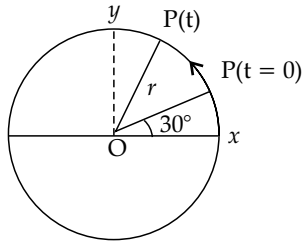

After time  $t$ , the angular displacement will be

$$\theta = \omega t$$

Total angular displacement from  $x$ -axis.

$$\theta_{\text{total}} = \omega t + \frac{\pi}{6} \quad \left( \because 30^\circ = \frac{\pi}{6} \right)$$

Now,  $OP$  has two component

The horizontal component will be the projection along  $x$ -axis

$$= r \cos(\theta_{\text{Total}}) = r \cos\left(\omega t + \frac{\pi}{6}\right)$$

18. Option (D) is correct.

$$m = m_0 \left(\frac{1}{2}\right)^n$$

$$\Rightarrow \frac{m_0}{8} = m_0 \left(\frac{1}{2}\right)^n$$

$$\Rightarrow \frac{1}{8} = \left(\frac{1}{2}\right)^3$$

$$\Rightarrow n = 3$$

3 days = 3 half life

1 day = 1 half life

Now

$$m = m_0 \left(\frac{1}{2}\right)^n$$

$$\Rightarrow 8 \times 10^{-3} = m_0 \left(\frac{1}{2}\right)^5$$

$$\Rightarrow m_0 = 32 \times 8 \times 10^{-3}$$

$$\Rightarrow m_0 = 256 \text{ g}$$

19. Option (C) is correct.

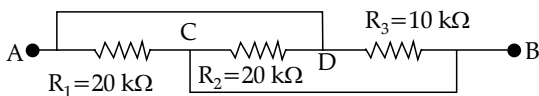

$$\text{Potential across } R_1 = V_A - V_C \quad (\because V_B = V_C)$$

$$= V_A - V_B$$

$$\text{Potential across } R_2 = V_D - V_C \quad (\because V_D = V_A)$$

$$= V_A - V_B$$

$$\text{Potential across } R_3 = V_D - V_B \quad (\because V_B = V_C)$$

$$= V_A - V_B$$

It means all the resistance are in parallel

$$\frac{1}{R_{\text{eq}}} = \frac{1}{R_1} + \frac{1}{R_2} + \frac{1}{R_3}$$

$$\Rightarrow \frac{1}{R_{\text{eq}}} = \frac{1}{20} + \frac{1}{20} + \frac{1}{10}$$

$$\Rightarrow \frac{1}{R_{\text{eq}}} = \frac{1+1+2}{20}$$

$$\Rightarrow R_{\text{eq}} = \frac{20}{4} = 5 \text{ k}\Omega$$

20. Option (B) is correct.

Intensity of incident light  $\propto$  photo current

So, A statement is correct

Now,  $K.E_{\text{max}} = h\nu - \phi$

$\therefore$  K.E. depends upon frequency

So, C statement is correct.

## Section B

21. The correct answer is (6)

$$U_i = \frac{1}{2} CV^2$$

$$U_i = \frac{1}{2} \times (600 \times 10^{-12}) \times (200)^2$$

$$U_i = 12 \mu\text{J}$$

Charge on capacitor  $\Rightarrow Q = CV$

$$Q = 600 \times 10^{-12} \times 200 = 12 \times 10^{-8} \text{ C}$$

When connected to another uncharged capacitor

$$Q' = \frac{Q}{2} = \frac{12 \times 10^{-8}}{2} = 6 \times 10^{-8} \text{ C}$$

$$U_f = 2 \times \frac{1}{2} \times \frac{Q'^2}{C} = \frac{Q'^2}{C}$$

$$\Rightarrow U_f = \frac{(6 \times 10^{-8})^2}{600 \times 10^{-12}} = 6 \mu\text{J}$$

$$\Delta E = U_f - U_i = (12 - 6) \mu\text{J} = 6 \mu\text{J}$$

22. The correct answer is (4).

$$R = 100 \Omega$$

$$L = 1 \text{ H}$$

$$C = 6.25 \times 10^{-6} \text{ F}$$

$$\omega = \frac{1}{\sqrt{LC}} = \frac{1}{\sqrt{1 \times 6.25 \times 10^{-6}}}$$

$$\Rightarrow \omega = 400/\text{s}$$

Now

$$Q_{\text{factor}} = \frac{\omega L}{R} = \frac{400 \times 1}{100} = 4$$

23. The correct answer is (125).

$$n = 8 \times 10^{28} \text{ m}^{-3}$$

$$A = 2 \times 10^{-6} \text{ m}^2$$

$$I = 3.2 \text{ A}$$

$$V_d = \frac{i}{enA} = \frac{3.2}{1.6 \times 10^{-19} \times 8 \times 10^{28} \times 2 \times 10^{-6}}$$

$$\Rightarrow V_d = 125 \times 10^{-6} \text{ m/s}$$

24. The correct answer is (75).

Total initial kinetic energy

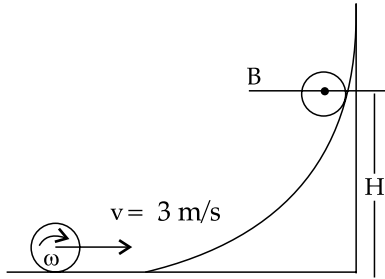

$$= \frac{1}{2}mv^2 + \frac{1}{2}I\omega^2$$

$$v = R\omega \text{ (for pure rolling)}$$

$$\text{K.E.C} = \frac{1}{2}mv^2 + \frac{1}{2} \times \frac{2}{3}mR^2 \times \frac{v^2}{R^2} = \frac{5}{6}mv^2$$

Energy remains conserve during whole journey.

$$\text{K.E.}_i + \text{P.E.}_i = \text{K.E.}_f + \text{P.E.}_f$$

$$\Rightarrow \frac{5}{2}mv^2 = mgH$$

$$(\because \text{K.E.}_f = 0)$$

$$\Rightarrow H = \frac{5}{6} \times \frac{v^2}{g}$$

$$= \frac{5 \times (3)^2}{6 \times 10}$$

$$= \frac{15}{20} \text{ m} = 0.75 \text{ m} = 75 \text{ cm}$$

25. The correct answer is (4).

$$\frac{\sigma}{E} = Y$$

$$\Rightarrow \sigma = YE = Y \frac{\Delta l}{l}$$

$$\Rightarrow \sigma = Y = \frac{l\alpha\Delta T}{l}$$

$$\Rightarrow \sigma = Y \alpha \Delta T$$

Now,

$$\sigma = \frac{F}{A}$$

$$\Rightarrow F = \sigma A = YA \alpha \Delta T$$

$$\Rightarrow F = 2 \times 10^{11} \times 10^{-4} \times 10^{-5} \times 200$$

$$= 4 \times 10^4$$

$$x = 4$$

26. The correct answer is (8).

Magnetic field due to current carrying coil on axis at distance  $d$ .

$$B_a = \frac{\mu_0 I r^2}{2(r^2 + d^2)^{\frac{3}{2}}}$$

Given that  $d = r$

$$\text{Now, } B_a = \frac{\mu_0 I r^2}{2(2r^2)^{\frac{3}{2}}} = \frac{\mu_0 I}{4\sqrt{2}r}$$

Magnetic field at centre of current carrying coil

$$B_c = \frac{\mu_0 I}{2r}$$

$$\frac{B_c}{B_a} = \frac{\mu_0 I}{2r} \times \frac{4\sqrt{2}r}{\mu_0 I} = \frac{2\sqrt{2}}{1} = \frac{\sqrt{8}}{1}$$

$$x = 8$$

27. The correct answer is (27).

$$\frac{1}{\lambda} = R \left( \frac{1}{n^2} - \frac{1}{m^2} \right) \text{ for balmer series } n = 2$$

Now, for  $H_{\alpha}$ ,  $m = 3$  and for  $H_{\beta}$ ,  $m = 4$

$$\text{Here, } \frac{1}{\lambda_{H_{\alpha}}} = R \left( \frac{1}{4} - \frac{1}{9} \right) = \frac{5R}{36}$$

$$\& \frac{1}{\lambda_{H_{\beta}}} = R \left( \frac{1}{4} - \frac{1}{16} \right) = \frac{3R}{16}$$

So,

$$\frac{1}{\lambda_{H_{\alpha}}} = \frac{5R}{36}$$

$$\frac{1}{\lambda_{H_{\beta}}} = \frac{3R}{16}$$

$$\Rightarrow \frac{\lambda_{H_{\alpha}}}{\lambda_{H_{\beta}}} = \frac{27}{20}$$

$$\Rightarrow \frac{\lambda_{H_{\alpha}}}{\lambda_{H_{\beta}}} = \frac{27}{20}$$

$$\therefore x = 27$$

28. The correct answer is (30).

Refraction through spherical surface is given by:

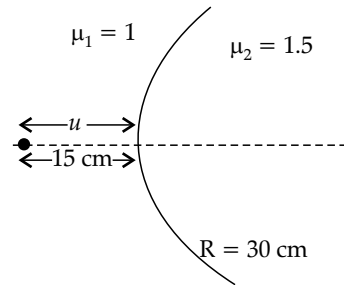

$$\frac{\mu_2}{V} = \frac{\mu_1}{u} = \frac{\mu_2 - \mu_1}{R}$$

$$\Rightarrow \frac{1.5}{V} - \frac{1}{-15} = \frac{1.5 - 1}{30}$$

$$\Rightarrow \frac{1.5}{V} + \frac{1}{15} = \frac{1}{60}$$

$$\Rightarrow \frac{1.5}{V} + \frac{1}{60} - \frac{1}{15} = \frac{1 - 4}{60}$$

$$\Rightarrow \frac{1.5}{V} = -\frac{3}{60} = -\frac{1}{20}$$

$$\Rightarrow V = -20 \times 1.5 = -30 \text{ cm}$$

29. The correct answer is (60).

$$l = \frac{\lambda}{2}$$

$$\Rightarrow \lambda = 2l$$

Now,  $v = f\lambda$

$$\Rightarrow f_1 = \frac{v}{\lambda} = \frac{v}{2l_1}$$



$$\Rightarrow f_1 \propto \frac{1}{l_1}$$

$$\Rightarrow f_2 \propto \frac{1}{l_2}$$

Here,

$$\frac{f_1}{f_2} = \frac{l_2}{l_1}$$

$$\Rightarrow \frac{120}{180} = \frac{l_2}{90}$$

$$\Rightarrow l_2 = 60 \text{ cm}$$

30. The correct answer is (30).

Given,  $P_i = 10 \text{ kg ms}^{-1}$

Now from Newton's second law

$$F = \frac{dP}{dt}$$

$$\Rightarrow F dt = dP$$

$$\Rightarrow 2 \times 5 = P_f - P_i$$

$$\Rightarrow 10 = P_f - 10$$

$$\Rightarrow P_f = 20 \text{ kg ms}^{-1}$$

$$\text{Now, } P_i = mV_i$$

$$10 = 5 \times V_i$$

$$\Rightarrow V_i = 2 \text{ ms}^{-1}$$

$$\text{and } P_f = 20 = mV_f$$

$$\Rightarrow 20 = 5 \times V_f$$

$$\Rightarrow V_f = 4 \text{ ms}^{-1}$$

$$\Delta \text{K.E.} = \text{K.E.}_f - \text{K.E.}_i = \frac{1}{2} \times 5 [(2)^2 - (4)^2]$$

$$= \frac{1}{2} \times 5 \times 12 = 30 \text{ J}$$