

JEE (Main) PHYSICS SOLVED PAPER

2023
29th Jan Shift 1

Section A

- Q. 1.** Find the mutual inductance in the arrangement, when a small circular loop of wire of radius 'R' is placed inside a large square loop of wire of side ($L \gg R$). The loops are coplanar and their centers coincide:

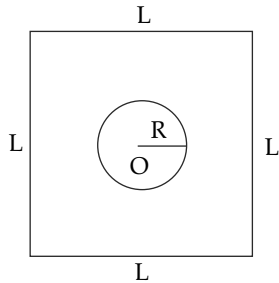

- (1) $M = \frac{\sqrt{2}\mu_0 R^2}{L}$ (2) $M = \frac{2\sqrt{2}\mu_0 R}{L^2}$
 (3) $M = \frac{\sqrt{2}\mu_0 R}{L^2}$ (4) $M = \frac{2\sqrt{2}\mu_0 R^2}{L}$

- Q. 2.** The threshold wavelength for photoelectric emission from a material is 5500 \AA . Photoelectrons will be emitted, when this material is illuminated with monochromatic radiation from a

- (A) 75 W infra-red lamp
 (B) 10 W infra-red lamp
 (C) 75 W ultra-violet lamp
 (D) 10 W ultra-violet lamp

Choose the correct answer from the options given below:

- (1) B and C only (2) A and D only
 (3) C only (4) C and D Only

- Q. 3.** Match List I with List II:

List I (Physical Quantity)	List II (Dimensional Formula)
A. Pressure gradient	I. $[M^0 L^2 T^{-2}]$
B. Energy density	II. $[M^1 L^{-1} T^{-5}]$
C. Electric Field	III. $[M^1 L^{-2} T^{-2}]$
D. Latent heat	IV. $[M^1 L^1 T^{-3} A^{-1}]$

Choose the correct answer from the options given below:

- (1) A – II, B – III, C – I, D – IV
 (2) A – II, B – III, C – IV, D – I
 (3) A – III, B – II, C – IV, D – I
 (4) A – III, B – II, C – I, D – IV

- Q. 4.** In a cuboid of dimension $2L \times 2L \times L$, a charge q is placed at the center of the surface 'S' having area of $4L^2$. The flux through the opposite surface to 'S' is given by

- (1) $\frac{q}{12\epsilon_0}$ (2) $\frac{q}{6\epsilon_0}$ (3) $\frac{q}{3\epsilon_0}$ (4) $\frac{q}{2\epsilon_0}$

- Q. 5.** A person observes two moving trains, 'A' reaching the station and 'B' leaving the station with equal speed of 30 m s^{-1} . If both trains emit sounds with frequency 300 Hz, (Speed of sound: 330 m s^{-1}) approximate difference of frequencies heard by the person will be:

- (1) 55 Hz (2) 80 Hz (3) 33 Hz (4) 10 Hz

- Q. 6.** A block of mass m slides down the plane inclined at angle 30° with an acceleration $\frac{g}{4}$. The value of coefficient of kinetic friction will be:

- (1) $\frac{1}{2\sqrt{3}}$ (2) $\frac{\sqrt{3}}{2}$ (3) $\frac{2\sqrt{3}+1}{2}$ (4) $\frac{2\sqrt{3}-1}{2}$

- Q. 7.** A bicycle tyre is filled with air having pressure of 270 kPa at 27°C . The approximate pressure of the air in the tyre when the temperature increases to 36°C is

- (1) 270 kPa (2) 262 kPa (3) 360 kPa (4) 278 kPa

- Q. 8.** A single current carrying loop of wire carrying current I flowing in anticlockwise direction seen from +ve z -direction and lying in xy -plane is shown in figure. The plot of j component of magnetic field (B_y) at a distance ' a ' (less than radius of the coil) and on yz -plane vs- z -coordinate looks like

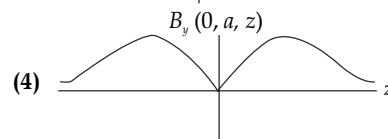
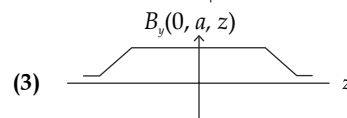
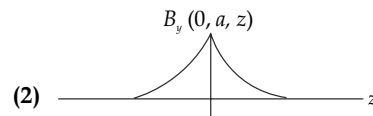
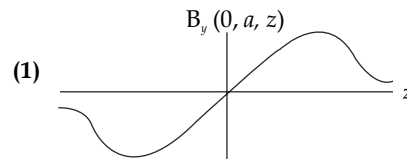
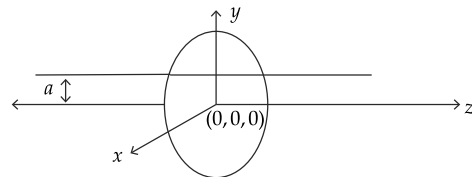

Q. 9. Surface tension of a soap bubble is $2.0 \times 10^{-2} \text{ Nm}^{-1}$. Work done to increase the radius of soap bubble from 3.5 cm to 7 cm will be:

Take $\left(\pi = \frac{22}{7}\right)$

- (1) $9.24 \times 10^{-4} \text{ J}$ (2) $5.76 \times 10^{-4} \text{ J}$
 (3) $0.72 \times 10^{-4} \text{ J}$ (4) $18.48 \times 10^{-4} \text{ J}$

Q. 10. Given below are two statements: One is labelled as Assertion A and the other is labelled as Reason R.

Assertion A: If dQ and dW represent the heat supplied to the system and the work done on the system respectively. Then according to the first law of thermodynamics $dQ = dU - dW$.

Reason R: First law of thermodynamics is based on law of conservation of energy. In the light of the above statements, choose the correct answer from the options given below:

- (1) Both A and R are correct and R is the correct explanation of A
 (2) A is not correct but R is correct
 (3) A is correct but R is not correct
 (4) Both A and R are correct but R is not the correct explanation of A

Q. 11. If a radioactive element having half-life of 30 min is undergoing beta decay, the fraction of radioactive element remains undecayed after 90 min will be

- (1) $\frac{1}{8}$ (2) $\frac{1}{2}$ (3) $\frac{1}{4}$ (4) $\frac{1}{16}$

Q. 12. Two particles of equal mass ' m ' move in a circle of radius ' r ' under the action of their mutual gravitational attraction. The speed of each particle will be:

- (1) $\sqrt{\frac{4Gm}{r}}$ (2) $\sqrt{\frac{Gm}{4r}}$ (3) $\sqrt{\frac{Gm}{r}}$ (4) $\sqrt{\frac{Gm}{2r}}$

Q. 13. If the height of transmitting and receiving antennas are 80 m each, the maximum line of sight distance will be:

- Given: Earth's radius = $6.4 \times 10^6 \text{ m}$
 (1) 28 km (2) 36 km (3) 32 km (4) 64 km

Q. 14. A car is moving on a horizontal curved road with radius 50 m. The approximate maximum speed of car will be, if friction between tyres and road is 0.34. (take $g = 10 \text{ m s}^{-2}$)

- (1) 17 m s^{-1} (2) 13 m s^{-1}
 (3) 22.4 m s^{-1} (4) 3.4 m s^{-1}

Q. 15. Ratio of thermal energy released in two resistors R and 3R connected in parallel in an electric circuit is:

- (1) 1 : 27 (2) 1 : 1 (3) 1 : 3 (4) 3 : 1

Q. 16. A stone is projected at angle 30° to the horizontal. The ratio of kinetic energy of the stone at point of projection to its kinetic energy at the highest point of flight will be :

- (1) 1 : 2 (2) 1 : 4 (3) 4 : 1 (4) 4 : 3

Q. 17. Which of the following are true?

- A. Speed of light in vacuum is dependent on the direction of propagation.
 B. Speed of light in a medium is independent of the wavelength of light.
 C. The speed of light is independent of the motion of the source.
 D. The speed of light in a medium is independent of intensity.

Choose the correct answer from the options given below:

- (1) C and D only (2) B and C only
 (3) A and C only (4) B and D only

Q. 18. In a Young's double slit experiment, two slits are illuminated with a light of wavelength 800 nm. The line joining A_1P is perpendicular to A_1A_2 as shown in the figure. If the first minimum is detected at P, the value of slits separation ' a ' will be:

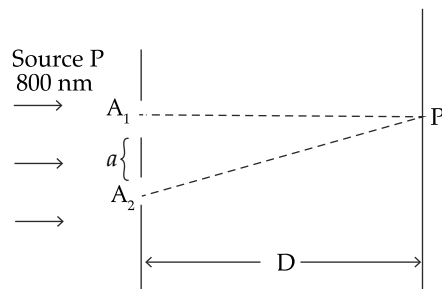

The distance of screen from slits, $D = 5 \text{ cm}$

- (1) 0.5 mm (2) 0.1 mm (3) 0.4 mm (4) 0.2 mm

Q. 19. Which one of the following statement is not correct in the case of light emitting diodes?

- A. It is a heavily doped p - n junction.
 B. It emits light only when it is forward biased.
 C. It emits light only when it is reverse biased.
 D. The energy of the light emitted is equal to or slightly less than the energy gap of the semiconductor used.

Choose the correct answer from the options given below:

- (1) A (2) C and D (3) C (4) B

Q. 20. The magnitude of magnetic induction at mid point O due to current arrangement as shown in Figure will be

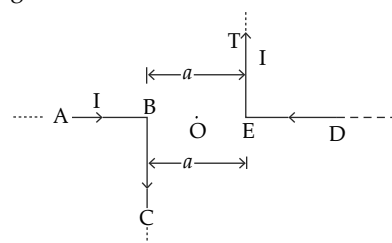

- (1) $\frac{\mu_0 I}{\pi a}$ (2) $\frac{\mu_0 I}{2\pi a}$ (3) 0 (4) $\frac{\mu_0 I}{4\pi a}$

Section B

- Q. 21. As shown in the figure, three identical polaroids P_1 , P_2 and P_3 are placed one after another. The pass axis of P_2 and P_3 are inclined at angle of 60° and 90° with respect to axis of P_1 . The source S has an intensity of 256 W m^{-2} . The intensity of light at point O is _____ W m^{-2} .

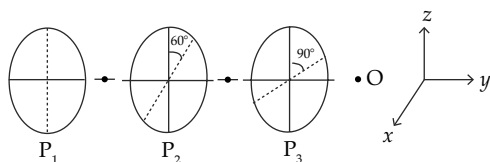

- Q. 22. A 0.4 kg mass takes 8 s to reach ground when dropped from a certain height 'P' above surface of earth. The loss of potential energy in the last second of fall is J.
(Take $g = 10 \text{ m/s}^2$)
- Q. 23. Two simple harmonic waves having equal amplitudes of 8 cm and equal frequency of 10 Hz are moving along the same direction. The resultant amplitude is also 8 cm . The phase difference between the individual waves is _____ degree.
- Q. 24. A tennis ball is dropped on to the floor from a height of 9.8 m . It rebounds to a height 5.0 m . Ball comes in contact with the floor for 0.2 s . The average acceleration during contact is m s^{-2}
(Given: $g = 10 \text{ m s}^{-2}$)
- Q. 25. A certain elastic conducting material is stretched into a circular loop. It is placed with its plane perpendicular to a uniform magnetic field $B = 0.8 \text{ T}$. When released the radius of the loop starts shrinking at a constant rate of 2 cm s^{-1} . The induced emf in the loop at an instant when the radius of the loop is 10 cm will be _____ m V.
(Given: $g = 10 \text{ m s}^{-2}$)
- Q. 26. A solid sphere of mass 2 kg is making pure rolling on a horizontal surface with kinetic energy 2240 J . The velocity of centre of mass of the sphere will be _____ m s^{-1} .
- Q. 27. A body cools from 60°C to 40°C in 6 minutes. If temperature of surroundings is 10°C . Then, after the next 6 minutes, its temperature will be _____ $^\circ\text{C}$.
- Q. 28. In a metre bridge experiment the balance point is obtained if the gaps are closed by 2Ω and 3Ω . A shunt of $X \Omega$ is added to 3Ω resistor to shift the balancing point by 22.5 cm . The value of X is.
- Q. 29. A point charge $q_1 = 4q_0$ is placed at origin. Another point charge $q_2 = -q_0$ is placed at $x = 12 \text{ cm}$. Charge of proton is q_0 . The proton is placed on x-axis so that the electrostatic force on the proton is zero. In this situation, the position of the proton from the origin is _____ cm.
- Q. 30. A radioactive element ${}^{242}_{92}\text{X}$ emits two α -particles, one electron and two positrons. The product nucleus is represented by ${}^{242}_P\text{Y}$. The value of P is.

Answer Key

Q. No.	Answer	Topic Name	Chapter Name
1	(4)	Mutual induction	EMI
2	(4)	Photoelectric emission	Photoelectric effect
3	(3)	Dimensional Formula	Units and Dimensions
4	(2)	Electric flux	Gauss's Law
5	(1)	Doppler's Effect	Sound Waves
6	(1)	Friction	Newton's laws of motion
7	(4)	Ideal gas equation	Kinetic theory of gases
8	(1)	Magnetic field due to current carrying loop	Moving charge and magnetism
9	(4)	Surface tension	Fluid mechanics
10	(1)	First law of Thermodynamics	Thermodynamics
11	(1)	Half life	Nuclear physics
12	(2)	Speed of an object in circular orbit	Gravitation
13	(4)	Line of sight	Communication Systems
14	(2)	Circular motion in horizontal plane	Circular motion
15	(4)	Heating effect of current	Electric current
16	(4)	Projectile motion	Motion in 2D
17	(1)	Refractive index	Ray optics
18	(4)	YDSE	Wave optics

19	(3)	Diode	Semiconductors
20	(1)	Magnetic field due to current carrying wire	Moving charge and magnetism
21	[24]	Polarisation	Wave optics
22	[300]	Mechanical energy	Work, Energy and Power
23	[120]	Superposition	SHM
24	[120]	Motion under gravity	Motion in 1D
25	[10]	Induced emf	EMI
26	[40]	Rotational kinetic energy	Rotational motion
27	[28]	Conduction	Heat Transfer
28	[2]	Galvanometer	Electric current
29	[24]	Coulomb's law	Electrostatics
30	[87]	Alpha decay	Nuclear Physics

SOLUTIONS

Section A

1. Option (4) is correct.

Let, A = area of circle
 B = magnetic field due to square
 I = Current in square

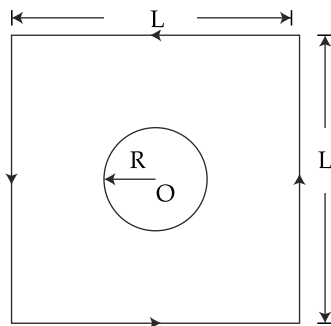

Since,

$$\begin{aligned} \phi &= MI \\ \Rightarrow \phi &= BA \\ \Rightarrow \phi &= \pi R^2 \left(4 \frac{\mu_0 I \sqrt{2}}{4\pi \left(\frac{L}{2}\right)} \right) \\ \Rightarrow \phi &= \frac{2\sqrt{2} \mu_0 R^2}{L} \end{aligned}$$

2. Option (4) is correct.

$\lambda < 55000 \text{ \AA}$ for photo electric effect
 $\lambda_{uv} < 5500 \text{ \AA}$

3. Option (3) is correct.

A. Pressure gradient = $\frac{dP}{dx} = \frac{[ML^{-1}T^{-2}]}{[L]}$
 $= [M^1L^{-2}T^{-2}]$

B. Energy density = $\frac{\text{Energy}}{\text{Volume}} = \frac{[ML^2T^{-2}]}{[L^3]}$

$$= [M^1L^{-1}T^{-2}]$$

C. Electric field = $\frac{F}{Q} = \frac{[MLT^{-2}]}{[AT]}$

$$= [M^1L^1T^{-3}A^{-1}]$$

D. Latent heat = $\frac{\text{Heat}}{\text{mass}} = \frac{[ML^2T^{-2}]}{[M]}$

$$= [M^0L^2T^{-2}]$$

4. Option (2) is correct.

This question can be solved by symmetry

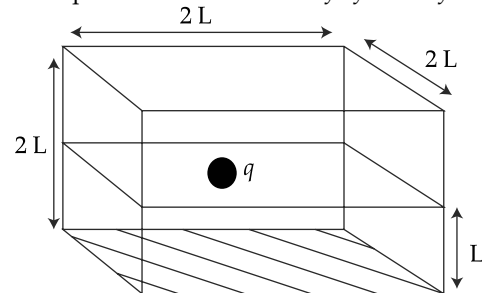

Now, $Q = \frac{q}{6}$

So, the flux passes through the shaded face = $\frac{q}{6\epsilon_0}$

5. Option (1) is correct.

$$f_1 = 300 \left[\frac{330 - 0}{330 - (-30)} \right] = 275 \text{ Hz}$$

$$f_2 = 300 \left[\frac{330 - 0}{330 - (30)} \right] = 330 \text{ Hz}$$

$$\Delta f = 330 - 275 = 55 \text{ Hz}$$

6. Option (1) is correct.

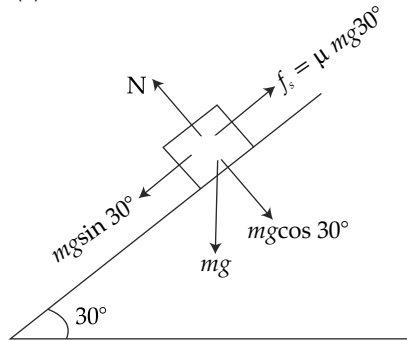

Resolving the force along inclined plane

$$mg \sin 30^\circ - \mu mg \cos 30^\circ = ma$$

$$\Rightarrow \frac{g}{2} - \frac{\sqrt{3}}{2} \mu g = \frac{g}{4}$$

$$\Rightarrow \frac{\sqrt{3}}{2} \mu = \frac{1}{4}$$

$$\Rightarrow \mu = \frac{1}{2\sqrt{3}}$$

7. Option (4) is correct.

$$P_1 = 270 \text{ kPa}$$

$$T_1 = 300 \text{ K}$$

$$T_2 = 309 \text{ K}$$

Taking volume constant

$$P_2 = \frac{P_1}{T_1} \times T_2$$

$$= \frac{270 \times 309}{300}$$

$$= 278 \text{ kPa}$$

8. Option (1) is correct.

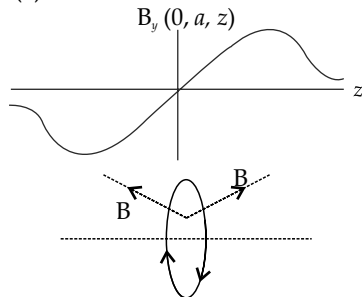

$B_y = 0$ in place of coil

B_y in opposite of each other in z and $-z$ positions.

9. Option (4) is correct.

Surface area of soap bubble = $2 \times 4\pi R^2$

Work done = change in surface energy $\times T_s$

$$W = T_s \times 8\pi \times (R_2^2 - R_1^2)$$

$$= 2 \times 10^{-2} \times 8 \times \frac{22}{7} \times 49 \times \frac{3}{4} \times 10^{-4}$$

$$= 18.48 \times 10^{-4} \text{ J}$$

10. Option (1) is correct.

First law of thermodynamics is based on law of conservation of energy and it can be written as

$$d\theta = dU - dW$$

where, dW is work done on the system.

11. Option (1) is correct.

$$\frac{N}{N_0} = \left(\frac{1}{2}\right)^{t/t_{1/2}} = \left(\frac{1}{2}\right)^{90/30}$$

$$\Rightarrow \frac{N}{N_0} = \left(\frac{1}{2}\right)^3 = \frac{1}{8}$$

12. Option (2) is correct.

$$\text{Here } \frac{Gm^2}{4r^2} = \frac{mv^2}{r}$$

$$\Rightarrow v = \sqrt{\frac{Gm}{4r}}$$

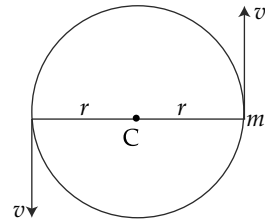

13. Option (4) is correct.

Maximum line of sight distance between two antennas is given by

$$dm = \sqrt{2Rh_T} + \sqrt{2Rh_R}$$

$$dm = 2 \times \sqrt{2 \times 6.4 \times 10^6 \times 80} = 64 \text{ km}$$

14. Option (2) is correct.

$$\text{We know that } f_s = \frac{mv^2}{r}$$

Maximum speed for safe turning

$$f_s = f_{s \text{ max}} = \mu mg$$

$$v_{\text{max}} = \sqrt{\mu rg}$$

$$= \sqrt{0.34 \times 50 \times 10} = 13 \text{ m/s}$$

15. Option (4) is correct.

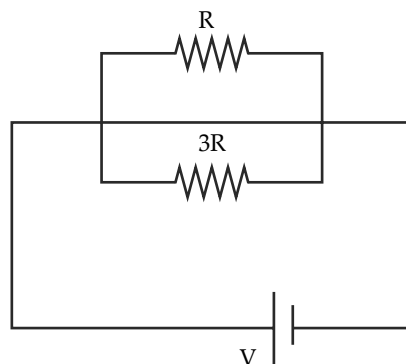

For parallel circuit

$$H = \frac{V^2}{R} \times t$$

$$\Rightarrow \frac{H_1}{H_2} = \frac{\frac{V^2}{R} \times t}{\frac{V^2}{3R} \times t} = \frac{3}{1}$$

$$\Rightarrow H_1 : H_2 = 3 : 1$$

16. Option (4) is correct.

Kinetic energy at point of projection

$$\text{K.E.}_{\text{pop}} = \frac{1}{2} mu^2$$

Now the kinetic energy at the top is

$$\text{K.E.}_{\text{Top}} = \frac{1}{2} m (u \cos 30^\circ)^2$$

By = 0 in plane of coil

By is opposite of each other in Z and -Z positions.

Ratio would be

$$\begin{aligned} \frac{\text{K.E.}_{\text{pop}}}{\text{K.E.}_{\text{Top}}} &= \frac{\frac{1}{2} mu^2}{\frac{1}{2} m (u \cos 30^\circ)^2} \\ &= \frac{1}{\left(\frac{\sqrt{3}}{2}\right)^2} = \frac{4}{3} \end{aligned}$$

17. Option (1) is correct.

Speed of light does not depend on the motion of source as well as intensity. And it does not depend upon source of light and intensity of light.

18. Option (4) is correct.

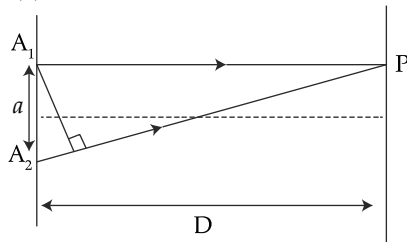

Here the path difference = $A_2P - A_1P$

$$\Rightarrow A_2P - A_1P = \frac{\lambda}{2} \quad [\text{Condition for minima}]$$

$$\Rightarrow \sqrt{D^2 + a^2} - D = \frac{\lambda}{2}$$

$$\Rightarrow D \left(1 + \frac{a^2}{D^2}\right)^{1/2} - D = \frac{\lambda}{2}$$

$$\Rightarrow D \left(1 + \frac{1}{2} \times \frac{a^2}{D^2}\right) - D = \frac{\lambda}{2}$$

$$\Rightarrow \frac{a^2}{2D} = \frac{\lambda}{2}$$

$$\begin{aligned} \Rightarrow a &= \sqrt{\lambda D} \\ &= \sqrt{800 \times 10^{-6} \times 50} \\ a &= 0.2 \text{ mm} \end{aligned}$$

19. Option (3) is correct.

LED works in forward biasing and light energy may be slightly less or equal to band gap.

20. Option (1) is correct.

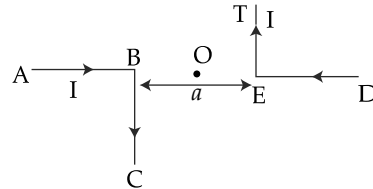

Here magnetic field due to current in BC and ET are outward at point 'O'.

Therefore,

$$B_0 = \frac{\mu_0 i}{4\pi r} + \frac{\mu_0 i}{4\pi r} = \frac{\mu_0 i}{2\pi r} = \frac{\mu_0 i}{\pi a}$$

Section B

21. The correct answer is [24].

By first polaroid P_1 intensity will be halved then P_2 and P_3 will make intensity $\cos^2(60^\circ)$ and $\cos^2(30^\circ)$ times respectively.

$$\begin{aligned} \text{Intensity out} &= \frac{256}{2} \times \frac{1}{4} \times \left(\frac{\sqrt{3}}{2}\right)^2 \\ &= \frac{256 \times 3}{2 \times 4 \times 4} = 24 \end{aligned}$$

22. The correct answer is [300].

Displacement in 8th second

$$S_8 = 0 + \frac{1}{2} \times 10 \times (2 \times 8 - 1)$$

$$S_8 = 5 \times 15 = 75 \text{ m}$$

Loss in potential energy

$$\begin{aligned} \Delta u &= mg\Delta h \\ &= 0.4 \times 10 \times 75 \\ &= 75 \times 4 \\ &= 300 \text{ J} \end{aligned}$$

23. The correct answer is [120].

According to the question

$$2A \cos\left(\frac{\Delta\phi}{2}\right) = A$$

$$\Rightarrow \cos\left(\frac{\Delta\phi}{2}\right) = \frac{1}{2}$$

$$\Rightarrow \frac{\Delta\phi}{2} = 60^\circ$$

$$\Rightarrow \Delta\phi = 2 \times 60 = 120 \text{ J}$$

24. The correct answer is [120].

Velocity of tennis ball before reaching the floor

$$V_i = \sqrt{2gh_i}$$

$$\begin{aligned}
 &= \sqrt{2 \times 10 \times 9.8} \downarrow \\
 &= 14 \text{ m s}^{-1} \downarrow \\
 V_f &= \sqrt{2gh_f} \\
 &= \sqrt{2 \times 10 \times 5} \uparrow
 \end{aligned}$$

$$\begin{aligned}
 \Rightarrow V_f &= \sqrt{100} \uparrow \\
 &= 10 \text{ m s}^{-1} \uparrow
 \end{aligned}$$

Now the average acceleration will be

$$\begin{aligned}
 |\bar{a}_{avg}| &= \left| \frac{\Delta V}{\Delta t} \right| \\
 &= \frac{10 - (-14)}{0.2} \\
 &= \frac{24}{0.2} = 120 \text{ m s}^{-2}
 \end{aligned}$$

25. The correct answer is [10].

We know that

$$\begin{aligned}
 \text{EMF} &= \frac{d\phi}{dt} \\
 \text{EMF} &= \frac{d}{dt} (B\pi r^2) \\
 &= 2B\pi r \frac{dr}{dt} \\
 &= 2 \times \pi \times 0.1 \times 0.8 \times 2 \times 10^{-2} \\
 &= 2\pi \times 1.6 \\
 &= 10.06 \approx 10 \text{ mV}
 \end{aligned}$$

26. The correct answer is [40].

Total kinetic energy of the sphere will be

$$\begin{aligned}
 \text{K.E.} &= \frac{1}{2} Mv^2 + \frac{1}{2} I\omega^2 \\
 \Rightarrow 2240 &= \frac{1}{2} \times 2 \times v^2 + \frac{1}{2} \times \frac{2}{5} \times 2R^2 \times \left(\frac{v}{R}\right)^2 \\
 \Rightarrow 2240 &= v^2 + \frac{2}{5} v^2 \\
 \Rightarrow 2240 &= \frac{7v^2}{5} \\
 \Rightarrow v^2 &= \frac{2240 \times 5}{7} \\
 \Rightarrow v^2 &= 1600 \\
 \Rightarrow v &= 40 \text{ m s}^{-1}
 \end{aligned}$$

27. The correct answer is [28].

By average form of Newton's law of cooling,

$$\frac{20}{6} = K(50 - 10) \quad \dots(i)$$

$$\frac{40 - T}{6} = K\left(\frac{40 + T}{2} - 10\right) \quad \dots(ii)$$

from equation (i) & (ii)

$$\Rightarrow \frac{20}{40 - T} = \frac{40}{10 + \frac{T}{2}}$$

$$\Rightarrow 10 + \frac{T}{2} = 80 - 2T$$

$$\Rightarrow \frac{5T}{2} = 70$$

$$\Rightarrow T = \frac{70 \times 2}{5} = 28^\circ\text{C}$$

28. The correct answer is [2].

For null point in metre scale

$$\frac{2}{\left(\frac{3x}{3+x}\right)} = \frac{40 + 22.5}{60 - 22.5} = \frac{62.5}{37.5} = \frac{5}{3}$$

$$\Rightarrow \frac{2(3+x)}{3x} = \frac{5}{3}$$

$$\Rightarrow 15x = 6(3+x)$$

$$\Rightarrow 15x = 18 + 6x$$

$$\Rightarrow 9x = 18$$

$$x = \frac{18}{9}$$

$$\Rightarrow x = 2$$

29. The correct answer is [24].

For net force zero on the proton, the net electric field must be zero.

Hence,

$$\frac{q_0}{x^2} = \frac{4q_0}{(x+12)^2}$$

$$\Rightarrow x + 12 = 2x$$

$$\Rightarrow x = 12$$

$$\begin{aligned}
 \text{So, the distance from origin} &= x + 12 \\
 &= 12 + 12 = 24 \text{ cm}
 \end{aligned}$$

30. The correct answer is [87].

$$P = 92 - 2 - 2 + 1 - 1 - 1 = 87$$

as per charge conservation principle.

•••